



**Profile
2021**

KARAM ALHABEEB COMPANY

+964 770 327 4935

+964 772 1116901

+964 780 942 0211

Mohammed@karam-alhabeeb.com

karam-alhabeeb.com



C O N T E N T S

Contents	01
Introduction	02
Our Services	06
Pipeline & Piping	07
Pipe Fittings Supply	08
General Contracting	09
Manpower	11
Heavy Vehicle	12
Our Projects	13





INTRODUCTION

Karam Al Habeeb Company is a Contracting Company based in Iraq with a diversified range of business in Oil and Gas, Petrochemicals, Civil Construction, Electrical works, Logistic and General Piping and Pipe Line works. Established in 2005 to initially meet the market demands for a service company who is able to deliver quality, innovation, and flexibility – a company that can respond quickly to customers' needs and support services possible in an ever-changing industry.

بسم الله الرحمن الرحيم
عقد تأسيس
شركة كرم الحبيب للمقاولات
العامة المحدودة

راسماليها 4000000000 أربعة مليارات دينار

أولاً: اسم الشركة: كرم الحبيب للمقاولات العامة المحدودة
ثانياً : مركز الشركة : البصرة ولها ان تفتح فروع أخرى داخل العراق وخارجه
ثالثاً : غرض الشركة وطبيعة العمل: تهدف الشركة الى المساهمة في استثمار
رؤوس الاموال في مجال المقاولات العامة والتي تتضمن:-

ا- المقاولات الانشائية وتشمل اعمال انشاء وتصميم وتوسيع وهدم المباني وكافة
الاعمال الصحية واعمال تعبيد الطرق وانشاء الطرق والجسور والسكك
والمطارات والسدود وجميع مشاريع الري والبزل وخزانات المياه واعمال تحريات
التربة واعمال الماء والمجاري .

ب- المقاولات الميكانيكية والكهربائية وتشمل الاعمال المتعلقة بنصب وتركيب
وصيانة المعدات والمكانن ومحطات توليد الكهرباء وبدالات الهوائف واعمال
التكييف والتاسيسات الكهربائية والصحية والمجاري والمصافي والابراج
والتركيبات المعدنية وغيرها من الاعمال التي تدخل في دائرة هذا الاختصاص.

وللشركة في سبيل تحقيق غرضها ونشاطها القيام بما يلي :

- أ.تملك الأموال المنقولة اللازمة لتحقيق نشاطها (من وسائل نقل مختلفة ، وعدد أدوات / وآلات وغيرها)
- ب.تملك كافة التصرفات القانونية عليها وفق القوانين النافذة أو التي تحل محلها .
- ج.القيام بكافة المعاملات المالية المسموح بها والتعامل بكافة المصارف المجازة داخل العراق .
- د .المساهمة في جميع الشركات تأسيساً وشراءً وبيعاً واندماجاً ما عدا (الشركات التضامنية) .
- هـ.مزاولة جميع الاعمال المسموح بها قانوناً وفق حاجة الشركة ومصنحة المساهمين وبما ينسجم مع القوانين النافذة .

و- شراء واستثمار وتأجير مختلف وسائل النقل والمكانن والرافعات والادوات الملقة والمتممة والتي
تدخل في نطاق اغراض الشركة.

ز- ان تجري جميع المعاملات وتبرم كافة عقودها وتوقع عليها وتدخل في مختلف انواع التعهدات
والمناقصات والمزايدات مع الدوائر الحكومية وكذلك دوائر القطاع العام والمختلط



واشخاص القطاع الخاص سواء كان بمفردها او لحسابها بالاشتراك مع الغير او لحساب الغير وكذلك التصرفات التي تراها لازمه لتنفيذ تلك الاغراض وبالشروط التي تراها مناسبة.
 ك- الاشتراك مع الاشخاص الطبيعيين والمعنويين وبالشكل التي تراه مناسبة لتحقيق هذه الاغراض بما في ذلك تأسيس الشركات والاندماج فيها وشراء اسمها وسندات استقراضها والاكتتاب فيها مع مراعات احكام القوانين النافذة بهذا الخصوص.
 ل- للشركة الحق في فتح الاعتمادات والحسابات الجارية لدى المصارف وان تنشأ او تسحب او تنقل او تتصرف باي صورة اخرى بالأوراق التجارية والسندات القابلة للتداول والاوراق المالية الاخرى من كمبيالات وحوالات وسندات شحن غيرها مهما كان نوعها.
 ي- الاستقراض من الجهات الرسمية والمصرفية وبالشروط التي تراها مناسبة سواء مقابل رهن موجودات الشركة او بدون ذلك.
 خ- القيام بكافة الاعمال او الاجراءات القانونية التي تراها لازمة او مناسبة لتسهيل تحقيق نشاطها.

رابعاً : رأسمال الشركة :

رأسمال الشركة / 4000000000 أربعة مليارات دينار
 مقسم الى / 4000000000 أربعة مليارات سهم قيمة السهم الواحد دينار واحد .

خامساً : المؤسسون .

نحن المؤسسون الموقعون في القوائم المرفقة طياً اتفقنا على تعديل عقد تأسيس الشركة المبين اسمها أعلاه ورأسمالها أعلاه .

قد خولنا السيد / المحامي عبد الحسين حميد الشناوه للقيام بعملية تعديل عقد تأسيس الشركة بمراجعة دائرة تسجيل الشركات ومراجعة أي دائرة أخرى تتطلبها عملية التعديل .



وكيل المؤسسين- القائم بالتعديل

الاسم: المحامي عبد الحسين حميد الشناوه

العنوان: البصرة- المعقل - شارع الساعة

تلفون/07801401964-07902826064-07711129937

البريد الإلكتروني:
a2h3s5@yahoo.com





اتحاد المقاولين العراقيين
Iraqi Contractors Federation

شهادة ممارسة مهنة

تؤيد بأن المقاول
إن رقم عضويته في الاتحاد
مصنف بالدرجة

شركة كرم الحبيب للمقاولات العامة
21505
انشائي : ثلاثة

منتتم الى اتحادنا بتاريخ : **2006/05/22**
وأشترآكه مسدد لغاية : **2020/12/31**
من قبل لجنة تصنيف المقاولين

علي فاخر السنائي
رئيس اتحاد المقاولين العراقيين



جمهورية العراق
اتحاد المقاولين العراقيين
REPUBLIC OF IRAQ
IRAQI CONTRACTORS FEDERATION

تاريخ الاصدار
العنوان
الاختصاص
تاريخ الانضمام
رقم جلسة التخطيط
تاريخها
رقم العضوية
رقم الهوية
تاريخ النفاذ

2020/01/28
بصرة
انشائي
2006/05/22
52
2013/12/17
21505
819
31/12/2020

ICF 3



جمهورية العراق
اتحاد المقاولين العراقيين
REPUBLIC OF IRAQ
IRAQI CONTRACTORS FEDERATION



اسم الشركة كرم الحبيب للمقاولات العامة
المدير المفوض حازم احمد علي

علي فاخر السنائي
رئيس الاتحاد





OUR SERVICES



Karam Al Habeeb Company offers a large number of oil and gas services such as pipeline and piping services, Electrical services, petrochemical services and civil and mechanical services for oil and gas fields, oil wells services, oil fields safety, manpower supply and other services.

Our company provides a full range of services to our customers in both the government and private sectors inside Iraq. KHCO have large Experience in building construction painting, Pipeline & piping, Petrochemical supply and Electrical services.

Pipeline & Piping

Karam Al Habeeb Company specializes in pipeline logistics such as pipe transloading from rail spur to yard or yard to right-of-way, pipe storage and racking, and yard identification, preparation and maintenance. This customized logistical plan gets the pipe where it needs to be – from the mill to the stringing line – via rail, barge and road. construction capabilities span any length or diameter. The company's reputation as the premier cross-country pipeline contractor was built on its capability to manage and execute multiple spreads in the toughest terrain. Through KHCO lteam of operating companies all construction can be completed turnkey from mechanized welding to pigging.





Pipe Fittings Supply

We optimize your stocks with you and create new opportunities. We raise the quality of your logistics and coordinate your demands in the supply chain. KHCO analyzes your specific need and offers a customized concept that will shape and optimize the logistic services needed. This will result in a clear budget calculation and an effective service for you.

The company provides a full range of products and materials, through integrated processes which allow a fast order service. We are experienced in distribution and stock management for all kinds of fittings, flanges, pipes, lined-clad and bored pipes, large-radius bends and special supplies for petrochemical, oil, gas and power industries for the production, transportation and transformation of energy.

General Contracting

When a company is hired as a general contractor, it means, that the company becomes responsible for the means and methods used to execute the construction within the project's established parameters. We give every project the same time and attention to ensure high-quality construction for the best value, because we want every owner to be completely satisfied. There's nothing "general" about the KHCO approach to a project: You pay for a specific vision, and we pay specific attention to ensure that your vision is realized.

The main services KHCO provides to its clients are:

Civil Work:

- Piling.
- Reinforced Concrete work.
- Road Crossing.
- Floor works & Tiling.
- Plastering & Rendering.
- Wood & Bricks works.
- Painting.
- Roofing & Ceiling.
- Asphalt & Concrete paving.
- Shuttering & Concreting.
- Road Crossing.
- Foundation works.

Finishing Work:

- Plaster work.
- Tiles work.
- Partition work.
- Paint work.
- Ceramic and Marble work.

ELECTRO-MECHANICAL WORK:

- Plumbing work.
- Sanitary work.
- HVAC work.
- Electrical work.
- Tele-communication work.
- CATV work.

Our Company is your one-stop resource for all your steel fabrication needs. It includes steel and plate material procurement as per the code requirement. KHCO owns a mechanical fabrication shop with all the required equipment for steel plate cutting, rolling, beveling and welding.

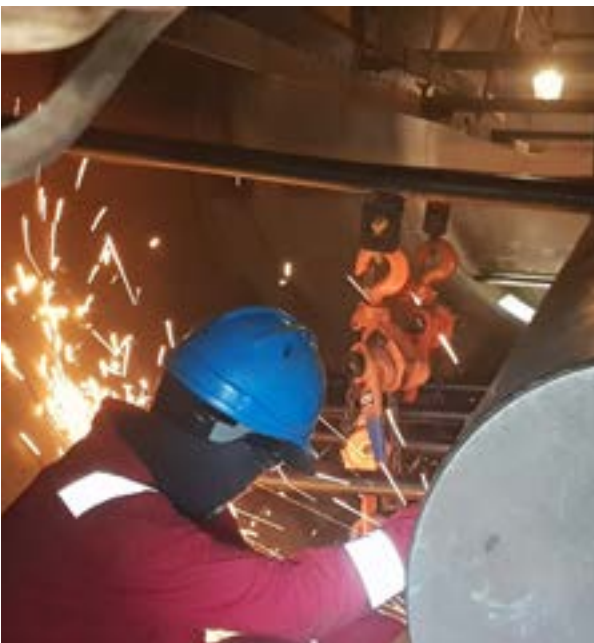



Manpower

KHCO offers exclusive service in recruitment process out sourcing professional staffing and organized labor supply, if required; through our highly qualified and dedicated team of recruiting team of recruitment professionals. Prospective candidates are thoroughly screened by our industry specific experts, for evaluation of their skill-sets, qualification, previous experiences and cost-effectiveness; to ensure recruitment of professionals best suited to each of the vacancies. We provide the entire range of manpower support service including permanent placement, contractual workforce as well as short-term and project based recruitment for each of these sectors. And regardless of the employment duration, every professional recruited through us comes with the Guarantee. We also assist the candidates in completing medical, ticketing, visa, emigration and other formalities, to ensure that our clients have a worry-free manpower

Designation	Qty.
Executive manage	1
Accounts	4
Information Technology	1
Human Resources	1
Civil Engineer	1
Electrical Engineer	1
Mechanical Engineer	3
Safety Engineer	2
HSE	3
Corporate lawyer	1
Land / Building Surveyors	4
Electricians	2
Mechanics	2
Construction	4
Drivers	100
Empoyler	120
Security	10
Welder	10
Total	270





Heavy Vehicle

Karam Al Habeeb Company has also built a high level of customer trust and satisfaction through our equipment availability and reliability, premium service and unparalleled value. Our company mission is to provide the best service in the industry, KHCO has workshop facilities to service, repair and maintain equipment. We strive to support our customers to the highest degree. We have more than 27 heavy vehicles as shown in the schedule.

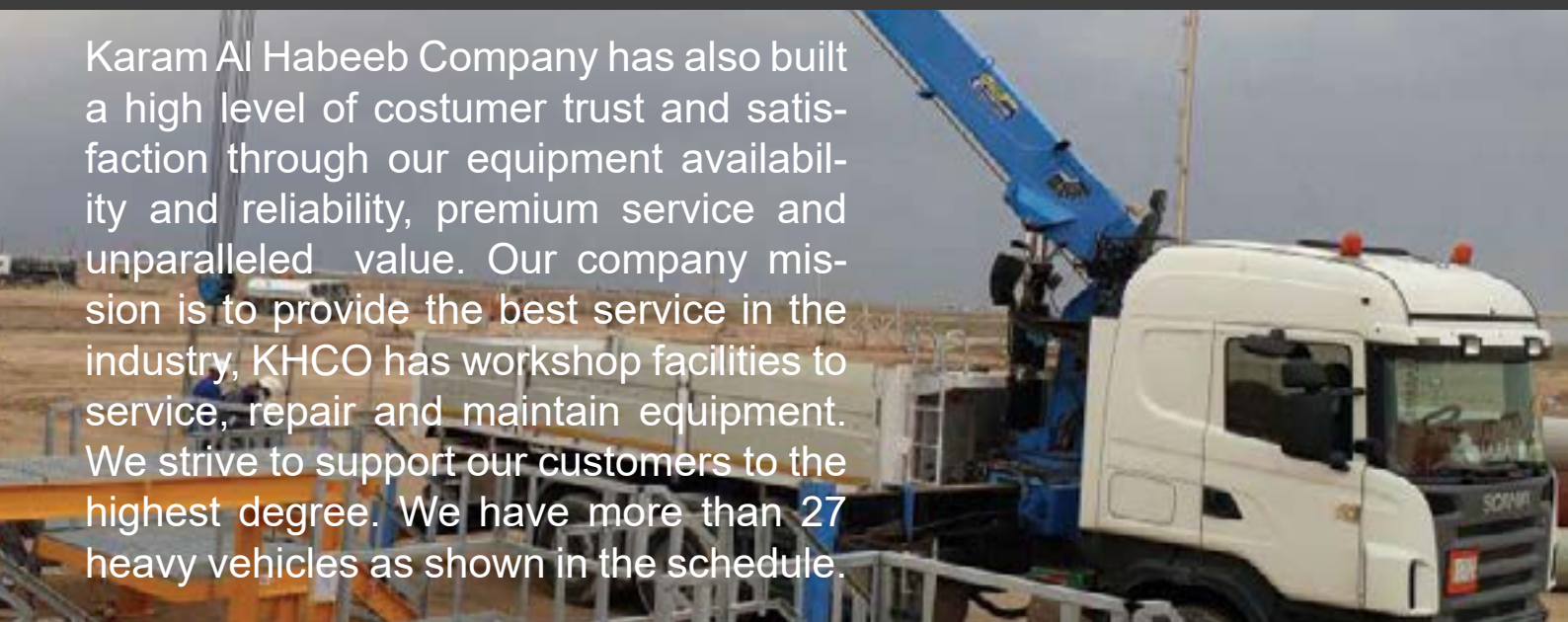

Designation	Qty.
Flat bed Truck	5
loader Truck	2
Loary	5
Shovel (Kawasaki)	3
Crane 50 Ton	2
Crane 80 Ton	2
Crane 100 Ton	3
Excavator (Hitachi)	2
Tank Truck 36 Ton	3
Total	27

OUR PROJECTS

Our company provided a full range of services to our customers. KHCO have large Experience in oil Refinery Pipeline construction and civil works services as sub-contractor company with SCDPI in Basra, Muthana, Baghdad and Kurdistan, Iraq.

Our projects included:

- Sand-blasting and painting of tanks and steel structures.
- Pipe work (isometric) design and construction.
- Oil gathering - flow stations, Gas gathering stations, Oil & gas pipelines.
- Electrical projects.
- Mechanical fitting supply.
- Construction and Welding Pipeline.
- Construction and installation and covering of Tanks.



Project	Client	Year
Construction of Extra lengths Bonding Pipes Network of Basra oil refinery.	State Company For Design & Projects Implementation	2017
Welding work of Pipe C.W.R.CWS24 in Basra oil refinery.	State Company For Design & Projects Implementation	2019
Construction and installation and covering of four tanks (5,000 Ton) for Samawah Oil Refinery.	State Company For Design & Projects Implementation	2017
Construction of Bonding Pipes Network between Refining units and Tanks for Sulaymaniyah Oil Refinery.	State Company For Design & Projects Implementation	2007
Construction and installation and covering of 17 tanks for Diwaniyah Oil Refinery.	State Company For Design & Projects Implementation	2009
Construction and installation of Refining unit (10,000) barrel per hour for Diwaniyah Oil Refinery.	State Company For Design & Projects Implementation	2013
Construction of Bonding Pipes Network between Unit, tanks, and energy of Basra oil refinery.	Techno Export	2012
Switch Valves of Gasoline Improvement Unit and construction of pipes to Electrical energy for Al Doura Oil Refinery.	State Company For Design & Projects Implementation	2018
project of painting the cooling towers (1,2) for Al Doura Oil Refinery.	State Company For Design & Projects Implementation	2018
Construction work of Compressor K404A & Roofs.	State Company For Design & Projects Implementation	2018
Construction work of new staion building.	State Company For Design & Projects Implementation	2018

Construction of Sulaymaniyah Oil Refinery



**KARAM
ALHABEEB COMPANY**

Construction and installation and covering of 17 tanks for Diwaniyah Oil Refinery.

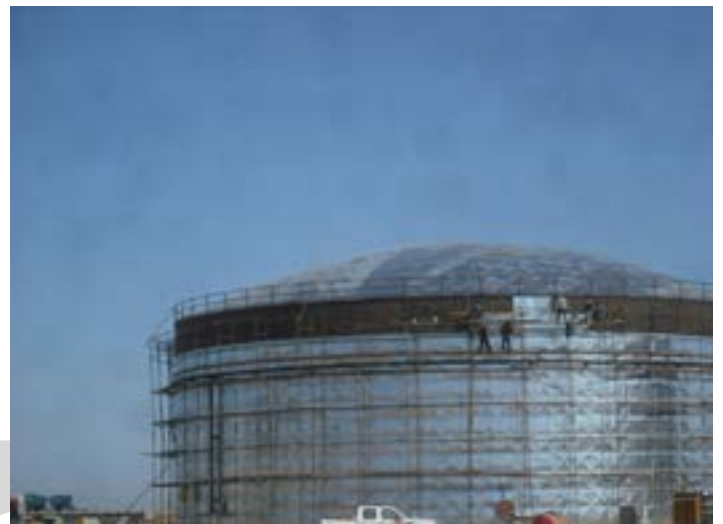

Construction and installation and covering of four tanks (5,000 Ton) for Samawah Oil Refinery.



**KARAM
ALHABEEB COMPANY**

Construction and installation of Refining unit (10,000) barrel per hour for Diwaniyah Oil Refinery.



**KARAM
ALHABEEB COMPANY**

project of painting the cooling towers (1,2) for Al Doura Oil Refinery.



**KARAM
ALHABEEB COMPANY**

Switch Valves of Gasoline Improvement Unit and construction of pipes to Electrical energy for Al Doura Oil Refinery.



Construction work of new staion building.



**KARAM
ALHABEEB COMPANY**

Construction work of Compressor K404A & Roofs.



ALHABEEB COMPANY



**Karam Alhabeeb Company
For General Contracting**

**شركة كرم الحبيب
للمقاولات العامة**

Mechanical Electrical Construction Supplying

تجهيز إنشاء كهرباء ميكانيك

Our Company Profile for Fire fighting



Company Profile

Thank you very much for giving us an opportunity to introduce us. We are one of best companies in general contracts and firefighting suppliers.

Karam Alhabeeb Company which is classified as fourth –construction, was established in 2003 as contractor bureau, in 2003 the office change to a company. It has more than 20 years in civilian, electrical and mechanical works and implemented more than 170 project in all regions of Iraq. The company is become the main branch of NAFFCO company with a vision to be the world's most recognized fire Protection Company through quality and development to save lives and properties. It is providers of firefighting equipment, fire protection system, fire alarm, security system and safety engineering under one proof.

The numerous projects executed by Karam Alhabeeb Company in both the private and government sectors throughout the Iraq are classic examples of its professional competency. These projects include residential buildings, commercial edifices (e.g. schools, hospitals, malls, sports stadiums, etc.), industrial manufacturing plants, power generation stations, and oil and gas facilities. As a provider of total fire protection systems Karam Alhabeeb Company undertakes turnkey projects from design, supply, installation, testing and commissioning of various systems like fire detection, fire alarm, fire suppression, and firefighting systems which our customers find it very convenient to have all their system requirements under one roof



RANGE OF SYSTEMS:

All types of Fire Extinguisher:

CO2, Dry Powder, Foam, Water, Wet Chemical and FE-36

Fire Hydrants

FM200 Suppression System

All types of valves

Sprinkler System

Deluge System

Water Mist System

Foam System

Carbon Dioxide System

Gas Detection System

Wet Chemical Suppression System

Fire Alarm System (Addressable and Conventional)

Fire Trucks

Ambulance

Industrial Safety Equipment

Emergency Lighting System

Dry and Wet Standpipe Systems

Fire Fighting Pumps (UL Listed and Non UL Listed)

- Vertical Turbine pump
- End Section Centrifugal Pump
- Horizontal Split Case Pump
- Vertical Multi Stage Centrifugal Jockey Pump
- Regeneration Turbine Jockey Pump



**Karam Alhabeeb Company
For General Contracting**

**شركة كرم الحبيب
للمقاولات العامة**

Mechanical Electrical Construction Supplying

تجهيز إنشاء كهرباء ميكانيك

K H PROJECT EXECUTED



SEFATY AND FIRE FIGHTING

NO	PROJECT	SCOPE	REMARKS	DATE
1	BRITAM	Fire Alarm System and Fire Extinguisher	Completed	2/2015
2	Basra Mas/Am Qaser	Fire alarm system	Completed	1/2015
3	South oil Company/ Ministry of oil	Exhaust Fan, Fire Extinguisher	Supply	9/2014
4	SKA	Design and Supply Fire pump system	Completed	9/2014
5	Basra Mas/ Marine Tower	Fire alarm system	Completed	9/2014
6	Missan Oil Company - Missan	H ₂ S Detector	Supplied	7/2014
7	Basra Mas/ Marine Building	Fire alarm system	Completed	7/2014
8	Basra Police Department	Design and Supply of FM-200 System	Complete	5/2014
9	Korak Company - Wasit	Firefighting Equipment	Supplied	3/2014
10	South oil Company/ Ministry of oil	400lit Foam, Cabinet	Supply	3/2014
11	EMC	Fire hose, Cabinets, Fire Extinguisher , Safety Equipment, Fire Alarm	Supply	2/2014
12	Nawaeer Al Khair	Hydrant Cabinets	Supply	2/2014
13	Iraqi Drilling Company - Missan	Powder Fire Extinguisher	Supplied	1/2014
14	State Company for Ports of Iraq	20 Firefighting Vehicle	Supply	1/2014
15	BAKER HUGHES	Fire Hydrant	Supply	1/2014
16	BAKER HUGHES	Design and Supply Fire Pump system,	Completed	12/2013
17	Eni Saipem	Fire Extinguisher (Dry Powder, Foam)	Supply	12/2013
18	Bazerkan power station - Missan	Design and Supply of FM-200 System	Completed	11/2013



N.	PROJECT	SCOPE	REMARKS	DATE
19	Ministry of Health	620 Ambulance	Supply	10/2013
20	Ministry of Health	620 Ambulance	Supply	10/2013
21	KorAlzober Power station	Design and supply fire alarm system	Completed	9/2013
22	Diesel power station – North Missan	Firefighting Equipment	Supplied	9/2013
23	Alfihai Company	Design and Supply Fire pump system and Fire alarm system	Completed	8/2013
24	kahlai power Station – Missan	H ₂ S Detector	Supplied	8/2013
25	kahlai power Station – Missan	H ₂ S Detector	Supplied	8/2013
26	DhiQar post office - DhiQar	Supply Fire Alarm System	Completed	8/2013
27	Missan Oil Company - Missan	Firefighting Equipment	Supplied	7/2013
28	Missan Oil Company - Missan	Multi H ₂ S Detector, H ₂ S	Supplied	6/2013
29	Basra Governorate Council	Design and Supply Fire pump system and Fire alarm system	Completed	5/2013
30	Missan Oil Company - Missan	Firefighting equipment (Dry powder, Co ₂ , Foam)	Supplied	5/2013
31	The Directorate production of electrical energy	Design and Supply of FM-200 System	Completed	4/2013
32	Gulf Company	Design and supply fire alarm system, Firefighting extinguisher	Completed	4/2013
33	SCHLUMBERGER	Fire Extinguisher	Supply	2/2013
34	Alraidh Company – kerbala / Najaf	Pumps 5 bar, Firefighting Materials	Supplied	1/2013
35	LUKOIL	Firefighting Vehicle	Supply	1/2013
36	Iraqi Drilling Company - Missan	Co ₂ and Powder Fire Extinguisher	Supplied	12/2012



**Karam Alhabeeb Company
For General Contracting**

**شركة كرم الحبيب
للمقاولات العامة**

Mechanical Electrical Construction Supplying

تجهيز إنشاء كهرباء ميكانيك

Below is one of our works that we specialize in with our distinguished cadres in polyethylene works, packaging and pipe laying works.





**Karam Alhabeeb Company
For General Contracting**

**شركة كرم الحبيب
للمقاولات العامة**

Mechanical Electrical Construction Supplying

ميكانيك كهرباء إنشائية تجهيز

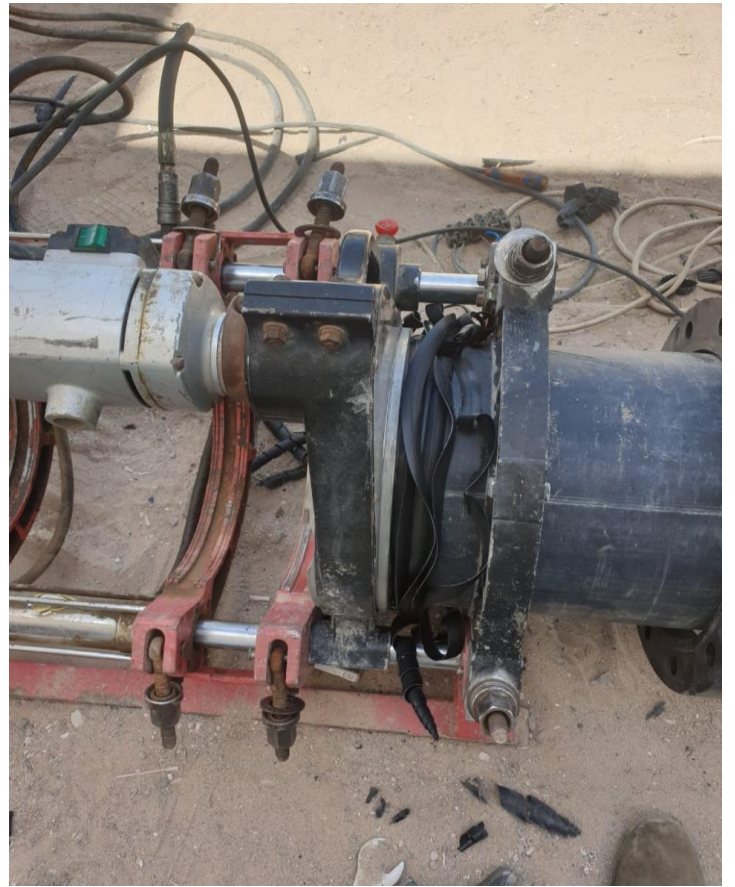



**Karam Alhabeeb Company
For General Contracting**

**شركة كرم الحبيب
للمقاولات العامة**

Mechanical Electrical Construction Supplying

تجهيز

إنشائية

كهرباء

ميكانيك





**Karam Alhabeeb Company
For General Contracting**

**شركة كرم الحبيب
للمقاولات العامة**

Mechanical Electrical Construction Supplying

تجهيز

إنشائية

كهرباء

ميكانيك





**Karam Alhabeeb Company
For General Contracting**

**شركة كرم الحبيب
للمقاولات العامة**

Mechanical Electrical Construction Supplying

تجهيز

إنشائية

كهرباء

ميكانيك





Karam Alhabeeb Company For General Contracting

شركة كرم الحبيب للمقاولات العامة

Mechanical Electrical Construction Supplying

ميكانيك كهرباء إنشائية تجهيز

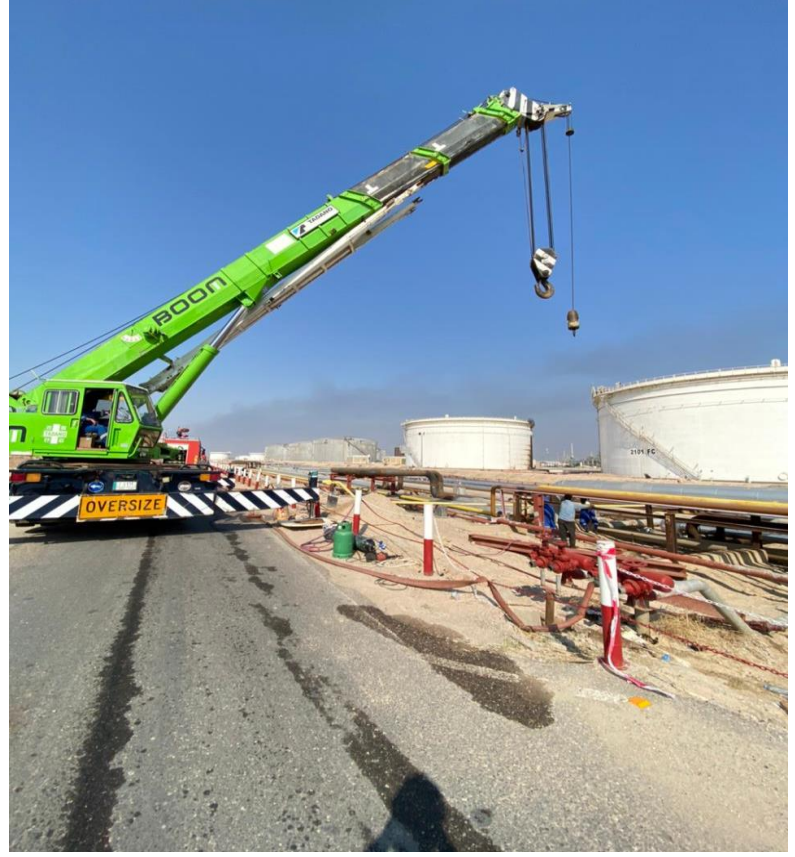



**Karam Alhabeeb Company
For General Contracting**

**شركة كرم الحبيب
للمقاولات العامة**

Mechanical Electrical Construction Supplying

تجهيز إنشاء كهرباء ميكانيك

CERTIFICATES OF APPROVALS





**Karam Alhabeeb Company
For General Contracting**

**شركة كرم الحبيب
للمقاولات العامة**

Mechanical Electrical Construction Supplying

تجهيز إنشاء كهرباء ميكانيك

PRODUCT OF FIRE FIGHTING EQUIPMENTS



Karam Alhabeeb Company
For General Contracting

شركة كرم الحبيب
للمقاولات العامة

Mechanical Electrical Construction Supplying

تجهيز إنشاءات كهرباء ميكانيك



جائزة محمد بن راشد آل مكتوم للأعمال
MOHAMMED BIN RASHID AL MAKTOUM BUSINESS AWARD
EXPOST 2005
المصنعة
MANUFACTURING 2006
الصناعة
MANUFACTURING 2010
JAFZA



FIRE FIGHTING EQUIPMENT



Carbon Dioxide Fire Extinguishers



0086



0086



PRODUCT DESCRIPTION

NAFFCO CO₂ gas extinguishers are characterised by their high performance for fires involving an electrical risk like computers, office equipment and generators etc. Co₂ is non conductive, clean and safe, ensuring minimal damage to electrical equipment and furnishings.

Suitable for Class B fire risks.

FEATURES

- Carbon dioxide in gaseous agent, colorless, odorless / non-toxic and provide rapid knock down of industrial fire. It is capable of fighting Class B fire effectively
- Kitemark Certified to BS EN3
- Cylinders compliance to council directive 97/23/EC (PED) and Statutory instrument 1999 No. 2001 is certified by BSI (0086)
- Certified by BSI under marine equipment directive
- Seamless steel body (Lightweight)
- High quality polyester paint
- Controlled discharge
- Brass head valve with simple squeeze operations provided with pressure relieve disc
- Rechargeable & easy to service
- Non conductive agent for electrical use without risk to operator
- CO₂ gas disappears quickly leaving no residue
- Swivel horn with no freeze burn, with greater directional control of CO₂ discharge through horn rotation feature
- 2Kg is available with the 55B Fire rating as efficient as 5Kg unit

Ideal Use: Chemical manufacturing plant, oil rigs, rail yards, warehouses, construction sites, parking garages, airport, boat and docks, and large laboratories

MODEL NUMBER	NC2	NCS2	NCZ2	NC2A	NC5	NC5X	NC5A	NCA5X
Extinguisher Capacity	2kg	2kg	2kg	2kg	5kg	5kg	5kg	5kg
Propellant	Self Propelling							
Fire Rating	34B	34B	55B	55B	55B	70B	55B	70B
Working Pressure	55-60 Bar @ 25 °C							
Maximum Operating Pressure	169 Bar @ 60 °C							
Test Pressure	250 Bar							
Total Weight	8,2kg	8,3kg	8,3kg	4,9kg	17,5kg	17,5kg	14,5kg	14,5kg
Range of Discharge	4-5m	4-5m	4-5m	4-5m	5-6m	5-6m	5-6m	5-6m
Duration of Discharge	8-9 sec	8-9 sec	10-12 sec	10-12 sec	10-12 sec	12-13 sec	10-12 sec	12-13 sec
Hose Length with Nozzle	N/A	N/A	N/A	N/A	750mm	750mm	750mm	750mm
Operating Temperature	-20 °C to +60 °C							
Cylinder Material	Carbon Steel	Carbon Steel	Carbon Steel	Aluminium	Carbon Steel	Carbon Steel	Aluminium	Aluminium
Height x Diameter (in mm)	610 x 101	610 x 101	610 x 101	472 x 111	730 x 139	730 x 139	575 x 159	575 x 159



1. Valve / Extn. Lever
2. Safety Pin with Chain
3. Valve Handle
4. Discharge Horn
5. Syphon Tube





Dry Powder Fire Extinguishers



PRODUCT DESCRIPTION

NAFFCO stored pressure type dry powder extinguishers are characterised by their high performance, simple method of operation and rapid fire knock down capability. They are suitable for tackling fires involving freely burning materials, petrol, oil, gas and electrical equipment. They are ideal for vehicle & marine risks. NAFFCO ABC powder extinguishers contain high performance powder and are one of the most powerful powder extinguishers in the world.

FEATURES

- Monoammonium phosphate based dry chemical agent. Capable of fighting Class A, B, C and E fires
- Kitemark certified to BS EN3
- Cylinders compliance to council directive 97/23/EC (PED) and Statutory instrument 1999 No.2001 is certified by BSI (0086)
- Certified by BSI under marine equipment directive
- High quality polyester paint
- Controlled discharge
- Brass nickel plated head valve with simple squeeze operation
- Unique gauge testing system
- Unique colour coded handle and base (Optional)
- Rechargeable and easy to service
- Choice of capacity from 1 to 12 Kg

Ideal Use: Houses, office, buildings, warehouses, farms, wood working area etc.

Note: Not recommended for use on expensive and delicate equipment like computers, etc.

MODEL NUMBER	NP1	NP2	NP3	NP4	NP6	NP6	NP9	NP12
Extinguisher Capacity	1kg	2kg	3kg	4kg	6kg	6kg	9kg	12kg
Propellant	95% Nitrogen + 5% Helium							
Fire Rating	8A 34B	13A 70B	21A 89B	21A 113B	34A 183B	43A 233B*	43A 233B	55A 233B
Working Pressure	14 Bar	14 Bar	14 Bar	15 Bar	15 Bar	15 Bar	15 Bar	15 Bar
Maximum Operating Pressure	16.5 Bar @ 60°C							
Test Pressure	30 Bar							
Total Weight	1.8kg	3.7kg	5.8kg	7.5kg	10 kg	14 kg	14 kg	17.8 kg
Range of Discharge	4-5m	5-7m	6-7m	7-8m	6-8m	7-8m	6-8m	6-8m
Duration of Discharge	7-9 sec	10-12 sec	11-12 sec	13-15 sec	18-20 sec	20-22 sec	22-24 sec	28-30 sec
Hose Length with Nozzle	N/A	N/A	395mm	457mm	534mm	534mm	524mm	617mm
Operating Temperature	-20°C to +60°C							
Cylinder Material	CRCA Steel Sheet							
Height x Diameter (in mm)	337 x 78	385 x 110	420 x 132	408 x 150	520 x 150	520 x 150	515 x 185	620 x 185

*High Fire Rating Using Special ABC Powder

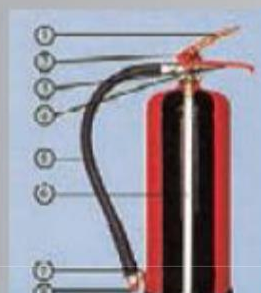

1. Valve / Extn. Lever
2. Safety Pin with Chain
3. Valve Handle
4. Pressure Gauge
5. Discharge Hose
6. Syphon Tube
7. Hose Holder
8. Discharge Nozzle
9. PVC Base



APPROVED ABC DRY POWDER MOBILE FIRE EXTINGUISHER

PRODUCT DESCRIPTION:

NAFFCO Mobile stored pressure ABC Dry powder extinguishers are characterized by their high performance and simple method operation. The ABC Dry powder Mobile type extinguisher contains high performance powder and thus has achieved highest fire rating.

They are suitable for multipurpose application of fires involving free burning materials, flammable liquids, flammable gases and electrical equipment.

Effective for Class A, B, C & Electrical fires



FEATURES:

- The fire extinguishers are designed to comply all the specification requirements of BS EN 1866-1
- Kitemark & LPCB approved for different capacity extinguishers.
- Highest fire rating due to high performance ABC powder.
- Ready for instant use and simple to operate.
- Fully controlled and easy operation by rust free brass valve.
- Cart and cylinder are made of rugged steel and welded to meet extreme use conditions.
- Easily transportable & Field rechargeable.
- Highly visible pressure-indicating gauge.
- Externally coated by Electrostatic powder painting after shot blasting ensures maximum corrosion resistance.
- Brass nickel plated head valve with simple lever operation.

Model	NTP 25	NTP 50	NTP 100
Extinguisher capacity	25 Kg	50 Kg	100 Kg
Fire Rating	IIB	IVB	IVB
Working Pressure	18 Bar	18 Bar	18 Bar
Maximum Working Pressure	21 Bar	21 Bar	21 Bar
Test Pressure	30 Bar	30 Bar	30 Bar
Total Height	990 mm	1060 mm	1050 mm
Total Weight	63 Kg	100 Kg	172 Kg
Range of Discharge	7-9m	7-9m	8-9m
Duration of Discharge	25-30 Sec	47-55 Sec	85-90 Sec
Operating Temperature	-20° C to +60°C	-20° C to +60°C	-20° C to +60°C
Propellant	Nitrogen	Nitrogen	Nitrogen
Hose size & Length	16mm x 5 mtr	16mm x 5 mtr	16mm x 7 Mtr
Material	Hot rolled Annealed steel plate		

TYPICAL DRY PILLAR HYDRANT INSTALLATION

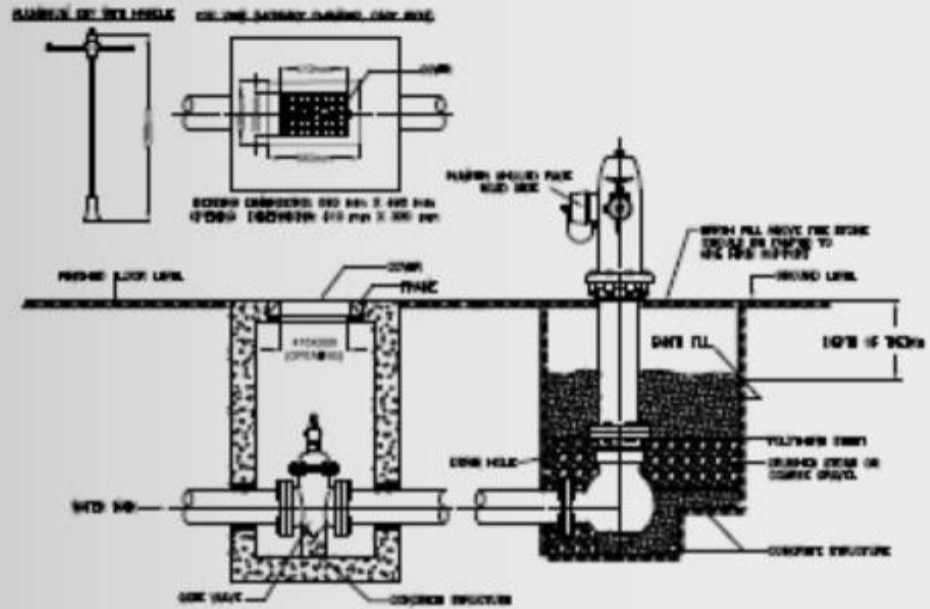

WET TYPE FIRE HYDRANT PEDESTAL TYPE

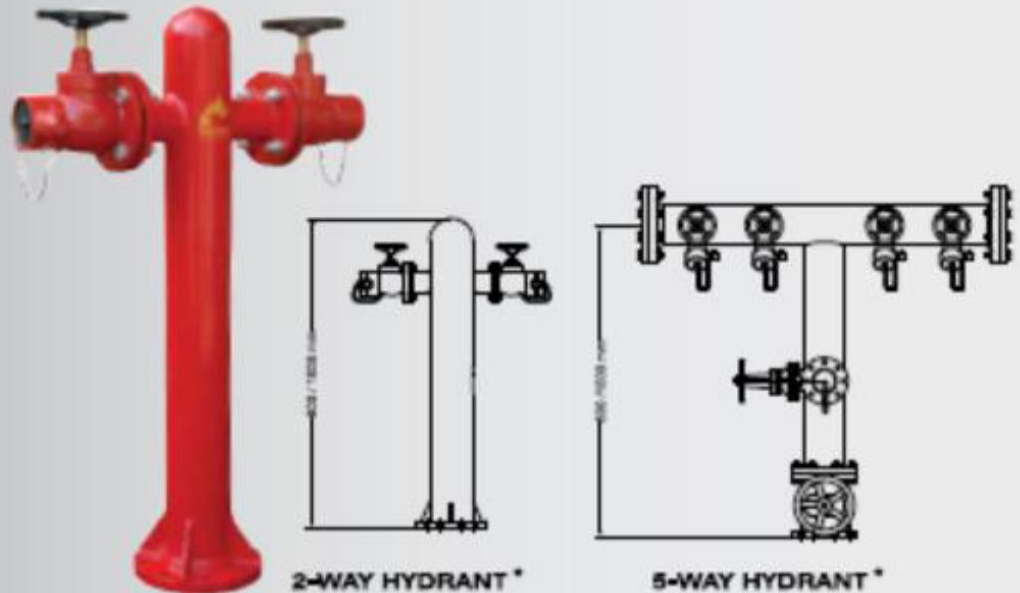

SPECIFICATIONS			
Model No	Base Flange (Inch)	Height of the Barrel (mm)	Nominal Working Pressure (Bar)
100NWH-800	4	800	16
100NWH-1000	4	1000	16
150NWH-800	6	800	16
150NWH-1000	6	1000	16

Optional:

*Hydrant outlet valve with different models available upon request.



Karam Alhabeeb Company
For General Contracting

Mechanical Electrical Construction Supplying

شركة كرم الحبيب
للمقاولات العامة

ميكانيك كهرباء إنشاءية تجهيز



جائزة محمد بن راشد آل مكتوم للأعمال
MOHAMMED BIN RASHID AL MUKTUM BUSINESS AWARD
التصانيف 2005 EXFO
الصناعة 2006 MANUFACTURING
الصناعة 2010 MANUFACTURING
2010

FIRE PUMPS





INTRODUCTION

The fire pumps are the heart of water based Fire Fighting System and we at NAFFCO ensures the proper functioning of this heart by the excellent design, manufacturing & installation. We uses the expertise of our well experienced engineers and design each pump set to suit the specific Fire Fighting System requirements, site conditions and the relevant standards. The quality of design is maintained throughout the process of manufacturing and our customers gets a 100% reliable pump set, Each pump sets are being tested for the performance as per the designed system requirements before dispatching from the factory. Being a ISO 9001:2000 registered firm, we implements stringent quality measures throughout the production which enables us to achieve the desired performance standards conforming to different regulations of NFPA, LPCB and Local Jurisdiction Authorities. The pumps delivered by us are covered by a standard warranty of one year, Currently around 35,000 NAFFCO packaged Fire Pump Sets are working worldwide in Government buildings, Warehouses, High rise Building, Factories, Residential buildings, etc. to protect the precious life and properties.

NAFFCO FIRE PUMP SET NPH SERIES

This model consist of one eclectic motor driven Fire Pump, diesel engine driven Fire Pump, one common Fire Pump controller, pressure vessel, standard accessories and base frame. The electric pump shall be vertical/horizontal multistage type close/flexibly coupled to electric motor. The electric motor is squirrel cage induction type, suitable for 3 phases, with required horse power rating. The diesel engine is fixed on the base with anti-vibration rubber pads and the pump is close / flexibly coupled to diesel engine. According to the power output of the engine the electrical system can be either 12V or 24V DC. The diesel engine consists of starter motor, fuel system, lubricating system, exhaust system etc.

The common controller is fabricated from mild steel and electrostatic powder coated to grey color. The enclosure is IP 54 rated and having all the required controls complying with the applicable standards (Local Jurisdiction Authority requirements, project specific requirements, etc.). The standard Fire Pump set will be complete with pressure switches, pressure gauge, suction & discharge manifolds with gate valves, non-return valves, flexible connectors, battery for diesel engine etc. All are mounted on a strong common base frame of mild steel and painted red.

Range for Fire Pump Set Model NPH Series

Flow Rate	Pressure
30 - 250 US GPM	3 - 10 Bar

Note: Higher ranges are available upon request

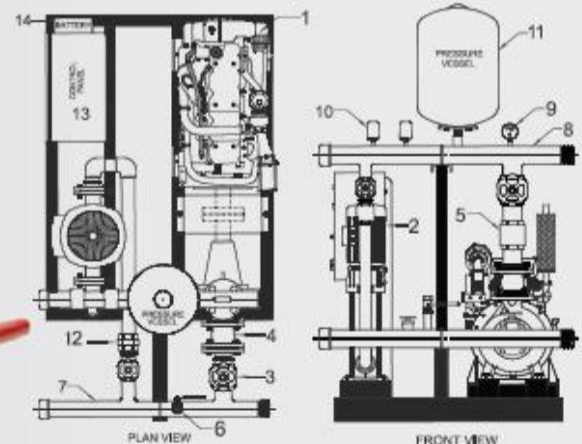

DESCRIPTION

1. DIESEL PUMP SET	5. NON RETURN VALVE	9. PRESSURE GAUGE	13. CONTROL PANEL
2. ELECTRIC PUMP	6. BALL VALVE	10. PRESSURE SWITCH	14. BATTERY
3. GATE VALVE	7. SUCTION MANIFOLD	11. PRESSURE VESSEL	
4. FLEXIBLE COUPLING	8. DELIVERY MANIFOLD	12. UNION	

NAFFCO FIRE PUMP SET NPS SERIES

This package consists of one main pump coupled to electric motor, one stand by pump coupled to diesel engine, jockey pump, pressure vessel, controller(s) for manual or automatic operation of the system and standard accessories on base frame(s). The electric pump shall be End Suction or Single Stage Horizontal split case or Horizontal multi stage centrifugal depending on the System capacity and head requirements. Electric motor is squirrel cage induction type and foot mounted suitable for 3 phases, with required horse power rating. The diesel engine is fixed on the base with anti-vibration rubber pads and the pump is directly coupled to a diesel engine through flexible coupling. According to the power output of the engine the electrical system can be either 12V or 24V DC.

The diesel engine consists of alternator, starter motor, fuel system, lubricating system, exhaust system, etc. The jockey pump is vertically mounted multi stage pump close coupled to TEFC, 3 phase motor. The controller shall be either common or individual (Electric, Diesel & Jockey) fabricated from mild steel and electrostatic powder coated to grey color. The enclosure is IP 54 rated and having all the required controls complying with the applicable standard (Local Jurisdiction Authority requirements). The standard Fire Pump set will be complete with pressure switches, pressure gauge, suction & discharge manifolds with gate valves, non-return valves, flexible connectors and battery for diesel engine. Pumps are mounted on strong individual or common base frame(s) of mild steel and painted red. This Fire Pump set is designed to be installed with the following Fire Protection Systems.

- Hose Reel System • Combined System.
- Deluge System (with modifications) • Stand Pipe System.
- Water Spray System • Sprinkler System.

Range for fire pump set model NPS series

Flow Rate	Pressure
300 - 2500 US GPM	5 - 18 Bar

Note: Higher ranges are available upon request



DESCRIPTION

1. ELECTRIC PUMP SET
2. DIESEL PUMP SET
3. JOCKEY PUMP
4. GATE VALVE
5. FLEXIBLE COUPLING
6. NON RETURN VALVE
7. BALL VALVE
8. SUCTION MANIFOLD
9. DELIVERY MANIFOLD
10. PRESSURE GAUGE
11. PRESSURE SWITCH
12. PRESSURE VESSEL

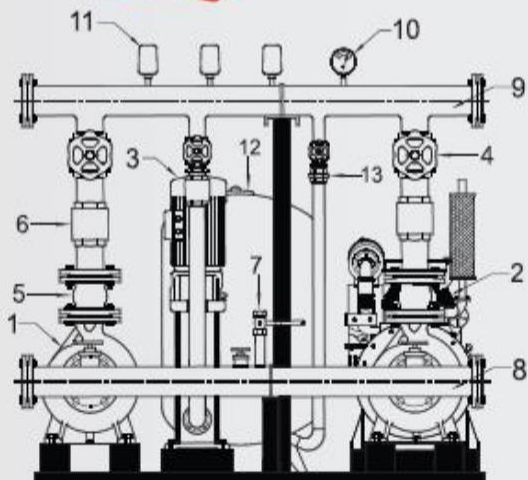



**Karam Alhabeeb Company
For General Contracting**

**شركة كرم الحبيب
للمقاولات العامة**

Mechanical Electrical Construction Supplying

تجهيز إنشاء كهرباء ميكانيك



FIRE FIGHTING AND RESCUE VEHICLE



MEDIUM DUTY FIRE FIGHTING VEHICLE NFM 60/50 - DC





Karam Alhabeeb Company
For General Contracting

شركة كرم الحبيب
للمقاولات العامة

Mechanical Electrical Construction Supplying

تجهيز إنشاء كهرباء ميكانيك





Karam Alhabeeb Company
For General Contracting

شركة كرم الحبيب
للمقاولات العامة

Mechanical Electrical Construction Supplying

تجهيز إنشاء كهرباء ميكانيك



To Secure the Safety of Work Force Worldwide



SAFETY & RESCUE

Fireman Gear



The ultimate fire & rescue helmets comfortable fire helmets

Thermoplastic LTX Helmets

Using the latest in engineering advancements, Bullard has developed the most comfortable low profile fire helmet on the market. With the re-engineered LT Series Helmet, you'll find more headroom than ever before. This advanced, lightweight thermoplastic structural fire helmet eliminates excess weight, reducing the stress and fatigue associated with bulkier helmets, without sacrificing protection

Features:

- Generous headroom
- Streamlined design
- Flexibility
- Compact package
- Sure Ratchet headband
- Tough and durable
- Quick, easy strapping
- Easy eye protection
- Cost effective

Note: Fire Helmets are available in different compositions like fiberglass, thermoplastic etc

Our fire helmets are NFPA compliant and have been certified to NFPA by safety Equipment Institute (SEI). NFPA compliance details are already mentioned on the label of each helmet. find out more about NFPA, check page 033-034.

Model	Product	Material	Color	Compliance
LTX	Fire Helmet	Thermoplastic	BL/RE/WH/YE/BU/OR/LY	NFPA1971, 2001
FXE	Fire Helmet	Fiberglass	BL/RE/WH/YE/BU/OR/LY	NFPA1971, 2001
Magma	Fire Helmet	Glass Fiber	RE/BU/WH/YE/BU/LY	EN443, EN14458, EN469
FH	Wildfire Helmet	Thermoplastic	BL/RE/WH/YE/BU/OR/LY	NFPA1977, 2005
USRX	Rescue Helmet	Thermoplastic	BL/RE/WH/YE/BU/OR/LY	NFPA1971, 2001
A1	Rescue Helmet	2Point chinstrap	RE/WH/YE/BU/OR	ANSI Z89.1 - 2003
A2	Rescue Helmet	3Point chinstrap	RE/WH/YE/BU/OR	ANSI Z89.1 - 2003

BL - Black/RE - Red/WH - White/YE - Yellow/BU - Blue/OR - Orange/LY - Lime Yellow



Safety Blankets

AJ075 - Used in emergency and rescue services to help protect against flame, treat shock or to smother flames on clothing. The flame resistant fiber is acid & high temperature resistant, 60"x80"

J61901 - Made of 100% wool and can be cleaned, 66"x90" used by rescue vehicles

AK242 - Helps the patient to be warm & dry providing insulation to retain body heat. Made of laminated urethane foam, 54" x80"

Model	Product	Material	Remarks
AJ075	Safety Blanket	Nomax	Emergency use to protect against flame, shock
J61901	Wool Blanket	Wool	Used in Rescue Vehicles
AK242	Disposable	Urethane Foam	Emergency usage disposable blanket

Personal Gas Detectors

(04) Personal Gas Detectors

- Multi Gas Detectors
- Explosive Gas Detectors
- Dosimeter
- Noise Level Readers
- Chemical Warfare Agent Detectors
- Metal Detection Systems
- Alcohol Detectors
- Ozone Detectors
- Radiation Detectors

Detectors are used by almost all personnel in oil and gas field rescue operations, fire fighting operations, confined space work, confined space rescue operations, waste management, well cleaning etc. detectors range from H₂S, O₂, CO, LEL etc to multi gas detectors for different purposes. Detectors will guard you against deadly gases by alerting you at the exact time there is a risk. Detectors are maintenance free, lightweight and come with calibration kits which can be modified to your requirements.



Points to note

Our feature rich detectors are designed for ease of use with field proven sensor technology.

- Large, status-at-a-glance displays
- Intelligent, automatic calibration—simply apply gas (the instrument checks that the calibration gas applied meets expected parameters)
- Unique, full function self-test verifies the integrity of all internal components
- Advanced programming techniques for user-friendly operational features and low training costs
- Data logging—use office standard programs (Excel, Access, etc.) to store, manage and display your data
- Lower maintenance costs
- Easy sensor replacement and field calibration
- Zero-maintenance, portable and fixed instruments
- Portable gas detectors use flexible power sources. Convenient local availability reduces operating costs.
- Local servicing available through authorized dealers.

Model Detects

100 Day Disposable Gas detectors

GA100-H	H ₂ S
GA100-M	CO

2 Years Maintenance free Detectors

GA24KT-H	H ₂ S
GA24KT-M	CO
GA24KT-S	SO ₂
GA24KT-X	O ₂

3 Years Maintenance free Detector

GA36XT-H	H ₂ S
GA36XT-M	CO

Single Gas Detector

GAXI-H	H ₂ S
GAXI-S	SO ₂
GAXI-O	NO ₂
GAXI-E	ETO
GAXI-N	NO
GAXI-M	CO
GAXI-C	Cl ₂
GAXI-A	NH ₃
GAXI-V	ClO ₂
GAXI-X	O ₂
GAXI-Z	HCN
GAXI-P	PH ₃
GAXI-G	O ₃

Carbon Monoxide Meter

CO Probe	CO
----------	----

Multi Gas Detectors

Gas Alert Micro Clip	H ₂ S, CO, O ₂ , LEL
Gas Alert Micro Clip	H ₂ S, O ₂ , LEL
Gas Alert Micro Clip	CO, O ₂ , LEL
Gas Alert Micro Clip	O ₂ , LEL
Gas Alert Micro Clip	H ₂ S, CO
Gas Alert Micro Clip	LEL

Other combinations are also available along with other detectors

Ventilators & Fans

(07) Ventilators / Fans

Positive Pressure Ventilator
Portable Ventilator / Industrial Fans
Ducts & Accessories
Confined Space Ventilators / Fans
Smoke Ejectors / Air Driven Ventilators

Ventilators and Fans For industrial and fire fighting designed to give the best efficiency for the required area whether usage is for industrial or fire and rescue purposes. The high performance turbo blowers are excellent for smoke extraction.



High Velocity turbo Blower U820 has high performance fan technology, lightweight and high strength polymers that allows maximum portability.

Characteristics Rugged durability and the highest airflow in its class, UB 20 can be attached with a quick couple reversible canister with attached duct conveniently reverses from discharge to suction making use and storage easier while protecting duct from rips and tears. Available with 4.6m and 7.6m of duct

Motor: 245W 220V 50Hz, Amps: Run - 1.2, Fan Size: 20 cm x 9 blade impeller, Weight: 7 Kgs, Dimensions: 36h x 32w x 33d (blower only), Air flow: 1392 cubic meter per hour (AC), 1,465 cubic meters per hour (DC)



Ecko Portable Ventilation Portable, dependable and good value ventilation fan

Characteristics The high performance 12 inch fan is the right choice for your high volume ventilation needs. Special features include a one piece cast aluminum impeller and rugged steel housing assuring long life and low maintenance. A unique sure grip handle and a built in on / off switch make set up and operation fast and easy. Four large rubber feet assure solid footing on slippery surfaces.

Phase: 1, Free Airflow: 2280 CFM, Weight: 35 lbs, Dimensions: 13 1/4" L x 12 1/2" W x 15 1/2" H



Blower / Exhauster The turbo Blower / Exhauster

Characteristics This portable blowers has a turbine blade design to achieve the higher pressure required to deliver a constant source of clean air even in the most difficult ventilation conditions. This 30 cms blower/exhauster cooling collar turns a turbo blower in to turbo cooler. A fine cooling mist of water can lower airflow temperature up to 14 degree Celsius

Motor: 230V 50Hz, Fan: 30 cms x 17 blade impeller, Amps: Start - 14, Run - 3 230V, Weight: 17 Kgs, Airflow: 3570 Cubic meter per hour in 50 Hz and 4250 Cubic meter per hour in 60 Hz, Dimensions: 41h x 38w x 41d cm

Model	Remarks
K1210	12" Ventilation - Voltage 115/230 - Frequency: 60 Hz
K1205	12" Ventilation - Voltage 220 - Frequency: 50 Hz
EF85	30 cms Blower / Exhauster - 660W
EF7500	30 cms Intrinsicly safe Blower / Exhauster
EF75	30 cms Blower / Exhauster - 560W
U820	Turbo Blower W/Turbo Ventilation System
U8200X	Intrinsicly Safe Turbo Blower
ED7002	8" standard AC Blower (U820) - 115V
ED7015	As ED7002 with w/Quick couple canister, w/15ft duct
ED7025	As ED7002 with w/Quick couple canister, w/25ft duct

Model	Remarks
EG8200	14" 1.5hp Blower - 115V or 230V w/16" adapter (EF1150)
EA8000	14" 1/2 hp Blower - 115V or 230V w/16" adapter (EF1150)
EB7201	12" 1/2 hp Blower - 115V or 230V w/12" adapter (EF1175)

Points to note

Different patterns with U820 can be adopted with separate ducts. In hazardous locations, intrinsicly safe ventilators are preferred

Karam Al Habib Company

Among the other important projects that have been implemented by our company
1- Parts of the water line feeding the Basra refinery, with a diameter of 24"

Where this line consists of a 24" polyethylene pipe, part of this line is under the ground and the other part is above the surface of the ground and contains many stations and connection points.

Our company has implemented its obligations under the contracts signed with the relevant authorities in the form of a sub-contractor using the latest techniques used in the work of separation, cutting and welding and under

((Welding procedure Prepared by the beneficiary authority and under the supervision of the inspecting authorities that praised the implementation work and as shown in the attached pictures.











2- The pipeline network of the boiler water treatment unit in the Basra refinery

One of the important projects implemented by our company is this project, where it carried out the works of separating, laying and welding the pipe network of the boiler water treatment unit for the Basra refinery, as well as lining works for filters with polyurea, which is characterized by its impact on chemicals, acid and salt.

Where the pipe network consists of different types of pipes, each according to the place in which it is used, and of these types (HDPE, ST.ST., C.ST) Where the main pipe feeding the unit was made of polyethylene, and the laying, separating and welding works were carried out according to the latest international methods and technical specifications approved by the relevant authorities in the Iraqi government. Shown in the pictures below









Thank you

For taking the time to go through this company profile. If there are any questions or comments, please feel free to contact us.

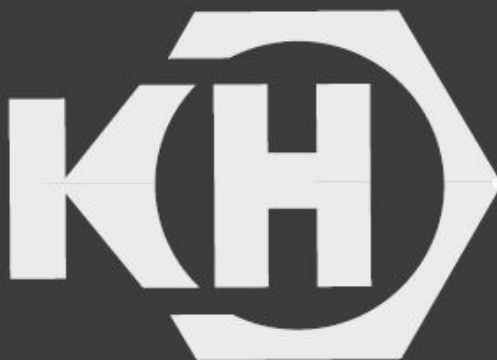

CONTACT US



+964 770 327 4935
+964 772 1116901
+964 780 942 0211



Iraq, Basra, Manwai Basha



Mohammed@karam-alhabeeb.com